

EXTRACTION TOOL	CONNECTOR	CONFIGURATION	NUMBER OF COMPLIANT PIN CONTACTS	NUMBER OF ALIGNMENT POSTS
2063012-1	2007669-1	2 x 8	15	16
2161554-1	2057004-2	2 x 12	19	24

Figure 1

1. INTRODUCTION

RJ Point Five Connector Extraction Tools are used to remove RJ Point Five connectors (see table in Figure 1 for part numbers) from the pc board.

Read these instructions thoroughly before using the extraction tool.

NOTE For application requirements of the connector, refer to Application Specification 114-13228.



NOTE Dimensions on this sheet are in metric units [with U.S. customary units in brackets]. Figures and illustrations are for reference only and are not drawn to scale.



2. DESCRIPTION (See Figure 1)

The extraction tool consists of a pin retainer plate, push pin holder, and guide block. The push pin holder contains the push pins (one for each connector pin contact and alignment post).

The pin retainer plate provides a surface to accept the force applied by the application tool to remove the connector from the pc board. The guide block can be adjusted to accommodate the thickness of the pc board (the contacts and alignment posts may or may not protrude from the pc board) for proper alignment with the extraction tool.

During removal, the push pins are forced through holes in the push pin holder, onto the contacts, and through the holes in the pc board.

3. REQUIREMENTS

3.1. PC Board Support Fixture (Customer Supplied)

A pc board support must be used to provide proper support for the pc board and to protect the pc board and the connector from damage. The support fixture must be designed for specific needs using the following recommendations:

- it should be at least 25.4 mm [1 in.] longer and wider than the pc board

— it should have a flat surface with a cutout of at least 35 mm [1.38 in.] deep (to allow adequate clearance for the connector)

3.2. Application Tooling

Power for the extraction tool must be provided by an application tool (with a ram) capable of supplying a downward force of 44.5 N [10 lb] per contact. For recommendation of application tools, contact PRODUCT INFORMATION at the number at the bottom of this page.

CAUTION  *Over-driving of the extraction tool could cause damage to the connector.*

4. EXTRACTION PROCEDURE

Determine whether the contacts protrude or do not protrude from the pc board, then proceed with the applicable instruction:

4.1. Contacts Protruding from PC Board (Figure 2)

1. Place the pc board (with the connector) on the pc board support fixture.
2. Grasp the guide block, and pull it down as far as it will go (the push pins should NOT protrude from the bottom of the push pin holder).
3. While holding the guide block in place, *carefully* position the extraction tool onto the pc board so that each contact enters a hole in the push pin holder.
4. Center the extraction tool (with the connector and support fixture) under the ram of the application tool. Slowly lower the ram until it just

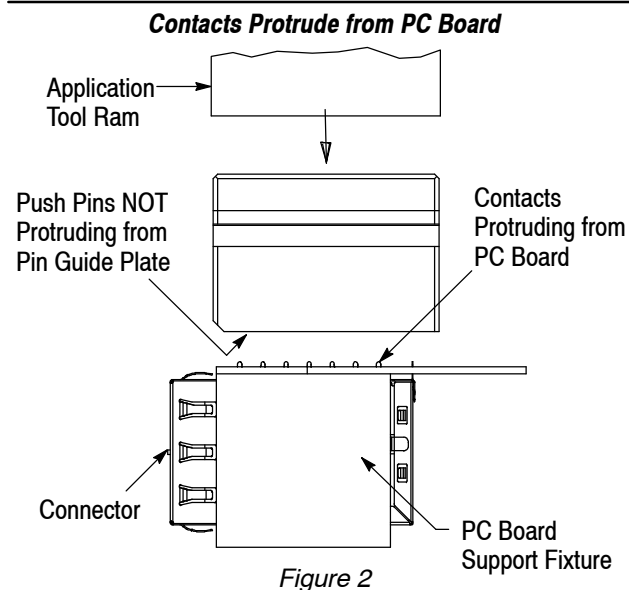

meets the extraction tool. Verify alignment of the support fixture, pc board, and extraction tool.

CAUTION  *Damage to the pc board or connector may occur if the extraction tool is not properly aligned with the ram before cycling the application tool.*

5. Cycle the application tool to remove the connector from the pc board. Then retract the ram, and carefully remove the extraction tool from the pc board.

4.2. Contacts NOT Protruding from PC Board (Figure 3)

1. Place the pc board (with the connector) on the pc board support fixture.
 2. Grasp the guide block, and push it up as far as it will go (the push pins should protrude from the bottom of the guide block).
 3. *Carefully* position the extraction tool onto the pc board so that each push pin enters a pc board hole containing a contact.
 4. Center the extraction tool (with connector, pc board, and support fixture) under the ram of the application tool. Slowly lower the ram until it just meets the extraction tool. Verify alignment of support fixture, pc board, connector, and extraction tool.
- CAUTION**  *Damage to the pc board or connector may occur if the extraction tool is not properly aligned with the ram before cycling the application tool.*
5. Cycle the application tool to remove the connector from the pc board. Then retract the ram, and carefully remove the extraction tool from the pc board.

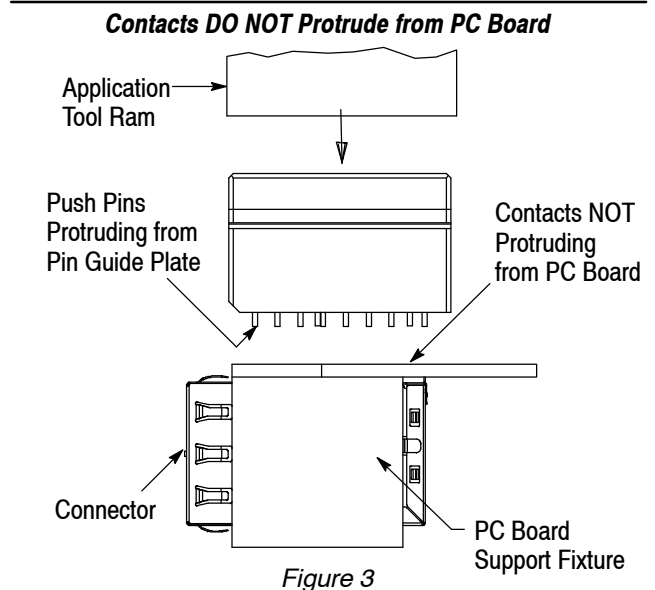

5. MAINTENANCE AND INSPECTION

The extraction tool is inspected before shipment. It is recommended that the extraction tool be inspected immediately upon arrival at your facility to ensure that it has not been damaged during shipment and that it conforms to the dimensions provided in Figure 4.

5.1. Daily Maintenance

It is recommended that each operator be made aware of, and responsible for, the following steps of daily maintenance:

1. Remove dust, moisture, and contaminants with a clean, soft brush or a lint-free cloth. **DO NOT** use objects that could damage the extraction tool components.
2. When the extraction tool is not in use, store it in a clean, dry area.

5.2. Periodic Inspection

Regular inspections should be performed by quality control personnel. A record of scheduled inspections should remain with the extraction tool or be supplied to personnel responsible for the extraction tool.

Inspection frequency should be based on amount of use, working conditions, operator training and skill, and established standards.

6. REPLACEMENT

Customer-replaceable parts are listed in Figure 4. A complete inventory should be stocked and controlled to prevent lost time when replacement of parts is necessary. Parts other than those listed should be replaced by TE Connectivity to ensure quality and reliability. Order replacement parts through your TE Representative, or call 1-800-526-5142, or send a facsimile of your purchase order to 717-986-7605, or write to:

CUSTOMER SERVICE (038-035)
 TYCO ELECTRONICS CORPORATION
 PO BOX 3608
 HARRISBURG PA 17105-3608

7. REVISION SUMMARY

- Updated document to corporate requirements
- Added or deleted text in Sections 1 and 2
- Added new table and information to Figures 1 and 4

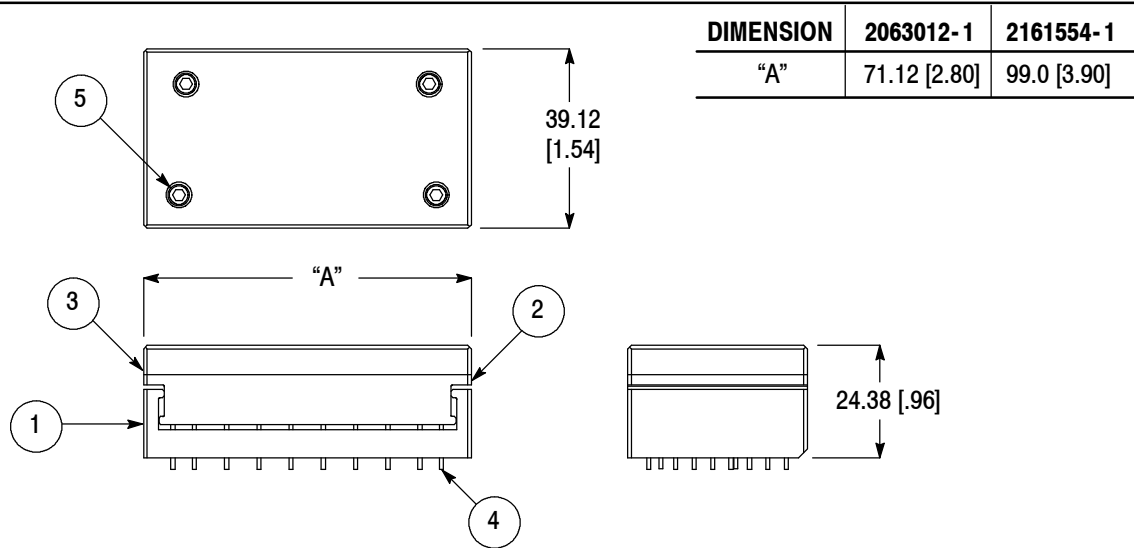

REPLACEMENT PARTS

ITEM	PART NUMBER		DESCRIPTION	QTY PER TOOL	
	2063012-1	2161554-1		2063012-1	2161554-1
1	2063199-1	2161576-1	GUIDE BLOCK	1	1
2	2063200-1	2161577-1	HOLDER, Push Pin	1	1
3	2063201-1	2161578-1	PLATE, Pin Retainer	1	1
4	1901636-1	1901636-1	PUSH PIN, .035-in. Diameter	31	43
5	1-21000-3	18023-3	SCREW, Socket Head Cap	4	4

Figure 4